

---

**GACO SARL**

28, Rue Bencharif Madani

25000 BELLEVUE/CONSTANTINE - ALGERIE

Tel. : 031 92 54 56 / 031 93 22 23 - Fax : 031 92 13 45

Email : gacosarl@gmail.com / benkobbi\_fares@yahoo.fr

**Type: Hermetic piston compressors****Producer: Danfoss-Maneurop****Series: MTZ****Model: MTZ56****Technical data**

Cylinder count:	2
Displacement [m <sup>3</sup> /h]:	16,73
Cylinder capacity [cm <sup>3</sup> ]:	96,1
RPM [min <sup>-1</sup> ]:	2900
Weight [kg]:	37
Oil charge [dm <sup>3</sup> ]:	2
Oil type:	160PZ
Crankcase heater type:	PTC 35 W
Maximum system test pressure low side / high side:	25 / 30
Maximum number of starts without softstart [1/h]:	12
Refrigerant charge limit [dm <sup>3</sup> ]:	5
Refrigerant:	R134a, 404A/R507, R407C
Sound power [dB]:	81
Sound power with acoustic hood [dB]:	74

**Connections**

	<u>inches</u>
Suction Rotolock valve connection:	1 3/4"
Discharge Rotolock valve connection:	1 1/4"
Suction connection with supplied sleeve:	7/8"
Discharge connection with supplied sleeve:	3/4"

**Approvals**

CCC	-
CE	+
UL	+

## R134a

**Cooling capacity [W]**

<b>t<sub>c</sub> \ t<sub>e</sub></b>	<b>-15</b>	<b>-10</b>	<b>-5</b>	<b>0</b>	<b>5</b>	<b>10</b>	<b>15</b>	<b>20</b>
<b>35</b>	3 715	5 063	6 719	8 723	11 117	13 941	17 235	21 042
<b>40</b>	3 309	4 592	6 167	8 074	10 354	13 049	16 199	19 845
<b>45</b>	2 934	4 141	5 624	7 423	9 580	12 135	15 130	18 604
<b>50</b>	2 596	3 717	5 097	6 779	8 802	11 207	14 036	17 329
<b>55</b>	2 303	3 328	4 596	6 149	8 028	10 273	12 926	16 028
<b>60</b>	-	2 982	4 127	5 542	7 266	9 341	11 807	14 706
<b>65</b>	-	-	-	4 965	6 524	8 418	10 688	13 374
<b>70</b>	-	-	-	-	-	7 512	9 575	12 038
<b>75</b>	-	-	-	-	-	-	8 476	10 706

**Power input [W]**

<b>t<sub>c</sub> \ t<sub>e</sub></b>	<b>-15</b>	<b>-10</b>	<b>-5</b>	<b>0</b>	<b>5</b>	<b>10</b>	<b>15</b>	<b>20</b>
<b>35</b>	1 874	2 083	2 273	2 437	2 566	2 652	2 686	2 660
<b>40</b>	1 919	2 146	2 359	2 550	2 710	2 831	2 906	2 925
<b>45</b>	1 950	2 198	2 437	2 657	2 852	3 012	3 130	3 197
<b>50</b>	1 965	2 237	2 504	2 758	2 989	3 191	3 355	3 472
<b>55</b>	1 962	2 261	2 559	2 848	3 120	3 366	3 579	3 750
<b>60</b>	-	2 265	2 598	2 925	3 240	3 534	3 799	4 026
<b>65</b>	-	-	-	2 988	3 349	3 693	4 012	4 299
<b>70</b>	-	-	-	-	-	3 840	4 217	4 565
<b>75</b>	-	-	-	-	-	-	4 410	4 823

**Current [A]**

<b>t<sub>c</sub> \ t<sub>e</sub></b>	<b>-15</b>	<b>-10</b>	<b>-5</b>	<b>0</b>	<b>5</b>	<b>10</b>	<b>15</b>	<b>20</b>
<b>35</b>	4.64	4.81	4.96	5.10	5.21	5.30	5.35	5.37
<b>40</b>	4.68	4.86	5.04	5.21	5.35	5.48	5.57	5.64
<b>45</b>	4.70	4.90	5.11	5.30	5.49	5.65	5.79	5.91
<b>50</b>	4.70	4.93	5.16	5.39	5.61	5.82	6.01	6.18
<b>55</b>	4.67	4.93	5.20	5.47	5.73	5.99	6.23	6.45
<b>60</b>	-	4.92	5.22	5.53	5.84	6.14	6.44	6.71
<b>65</b>	-	-	-	5.58	5.93	6.29	6.64	6.98
<b>70</b>	-	-	-	-	-	6.43	6.84	7.24
<b>75</b>	-	-	-	-	-	-	7.03	7.50

## Mass flow [kg/s]

$t_c \setminus t_e$	-15	-10	-5	0	5	10	15	20
35	82.91	110.70	143.88	183.11	229.01	282.22	343.37	413.10
40	77.05	104.76	137.81	176.84	222.49	275.39	336.17	405.47
45	71.60	98.95	131.59	170.16	215.28	267.59	327.73	396.33
50	66.75	93.47	125.42	163.24	207.56	259.02	318.24	385.87
55	62.67	88.48	119.48	156.28	199.52	249.85	307.88	374.26
60	-	84.18	113.94	149.45	191.34	240.26	296.82	361.68
65	-	-	-	142.93	183.20	230.43	285.26	348.32
70	-	-	-	-	-	220.55	273.36	334.35
75	-	-	-	-	-	-	261.32	319.96

## C.O.P. [W/W]

$t_c \setminus t_e$	-15	-10	-5	0	5	10	15	20
35	1.98	2.43	2.96	3.58	4.33	5.26	6.42	7.91
40	1.72	2.14	2.61	3.17	3.82	4.61	5.57	6.78
45	1.50	1.88	2.31	2.79	3.36	4.03	4.83	5.82
50	1.32	1.66	2.04	2.46	2.94	3.51	4.18	4.99
55	1.17	1.47	1.80	2.16	2.57	3.05	3.61	4.27
60	-	1.32	1.59	1.89	2.24	2.64	3.11	3.65
65	-	-	-	1.66	1.95	2.28	2.66	3.11
70	-	-	-	-	-	1.96	2.27	2.64
75	-	-	-	-	-	-	1.92	2.22

Operating conditions: suction superheat: 11.1 K, subcooling: 8.3 K

$t_c$  - Condensing temperature [°C]

$t_e$  - Evaporating temperature [°C]

## Application range

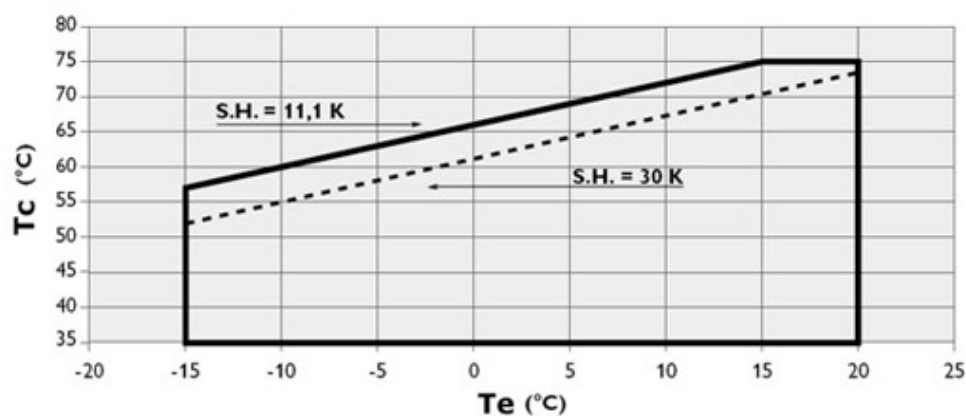

**GACO SARL**

28, Rue Bencharif Madani

25000 BELLEVUE/CONSTANTINE - ALGERIE

Tel. : 031 92 54 56 / 031 93 22 23 - Fax : 031 92 13 45

Email : gacosarl@gmail.com / benkobbi\_fares@yahoo.fr

**R404A/R507****Cooling capacity [W]**

<b>t<sub>c</sub> \ t<sub>e</sub></b>	<b>-30</b>	<b>-25</b>	<b>-20</b>	<b>-15</b>	<b>-10</b>	<b>-5</b>	<b>0</b>	<b>5</b>	<b>10</b>
<b>30</b>	3 487	4 805	6 438	8 424	10 801	13 608	16 883	20 664	24 991
<b>35</b>	2 894	4 170	5 733	7 620	9 871	12 523	15 616	19 187	23 275
<b>40</b>	2 366	3 581	5 053	6 823	8 928	11 406	14 297	17 638	21 468
<b>45</b>	1 912	3 045	4 408	6 041	7 980	10 265	12 934	16 025	19 578
<b>50</b>	1 539	2 572	3 806	5 281	7 036	9 107	11 535	14 358	17 613
<b>55</b>	-	2 169	3 255	4 554	6 104	7 943	10 110	12 643	15 582
<b>60</b>	-	1 845	2 764	3 866	5 192	6 779	8 666	10 891	13 493

**Power input [W]**

<b>t<sub>c</sub> \ t<sub>e</sub></b>	<b>-30</b>	<b>-25</b>	<b>-20</b>	<b>-15</b>	<b>-10</b>	<b>-5</b>	<b>0</b>	<b>5</b>	<b>10</b>
<b>30</b>	2 204	2 563	2 908	3 225	3 501	3 724	3 881	3 958	3 943
<b>35</b>	2 302	2 672	3 034	3 375	3 682	3 942	4 143	4 272	4 315
<b>40</b>	2 369	2 753	3 137	3 506	3 849	4 152	4 402	4 587	4 692
<b>45</b>	2 404	2 808	3 219	3 622	4 004	4 354	4 658	4 904	5 077
<b>50</b>	2 410	2 838	3 280	3 721	4 149	4 551	4 913	5 224	5 469
<b>55</b>	-	2 844	3 322	3 806	4 284	4 742	5 168	5 549	5 871
<b>60</b>	-	2 828	3 346	3 878	4 410	4 929	5 424	5 879	6 284

**Current [A]**

<b>t<sub>c</sub> \ t<sub>e</sub></b>	<b>-30</b>	<b>-25</b>	<b>-20</b>	<b>-15</b>	<b>-10</b>	<b>-5</b>	<b>0</b>	<b>5</b>	<b>10</b>
<b>30</b>	4.78	5.20	5.61	5.98	6.31	6.58	6.77	6.88	6.89
<b>35</b>	4.95	5.38	5.81	6.22	6.59	6.91	7.17	7.34	7.43
<b>40</b>	5.06	5.52	5.98	6.42	6.84	7.22	7.55	7.80	7.97
<b>45</b>	5.13	5.61	6.11	6.60	7.07	7.52	7.92	8.26	8.52
<b>50</b>	5.14	5.66	6.20	6.74	7.28	7.80	8.28	8.71	9.07
<b>55</b>	-	5.66	6.25	6.85	7.46	8.05	8.62	9.15	9.62
<b>60</b>	-	5.62	6.26	6.93	7.62	8.30	8.96	9.59	10.17

### Mass flow [kg/s]

$t_c \setminus t_e$	-30	-25	-20	-15	-10	-5	0	5	10
<b>30</b>	98.16	133.72	175.27	223.54	279.25	343.12	415.87	498.21	590.88
<b>35</b>	85.95	122.40	164.71	213.59	269.77	333.96	406.89	489.27	581.84
<b>40</b>	75.77	112.54	155.02	203.93	259.99	323.93	396.47	478.32	570.20
<b>45</b>	67.58	104.09	146.17	194.53	249.91	313.02	384.58	465.32	555.95
<b>50</b>	61.37	97.04	138.14	185.39	239.50	301.20	371.22	450.26	539.06
<b>55</b>	-	91.37	130.91	176.46	228.73	288.45	356.34	433.12	519.51
<b>60</b>	-	87.06	124.46	167.73	217.59	274.75	339.93	413.86	497.27

### C.O.P. [W/W]

$t_c \setminus t_e$	-30	-25	-20	-15	-10	-5	0	5	10
<b>30</b>	1.58	1.87	2.21	2.61	3.08	3.65	4.35	5.22	6.34
<b>35</b>	1.26	1.56	1.89	2.26	2.68	3.18	3.77	4.49	5.39
<b>40</b>	1.00	1.30	1.61	1.95	2.32	2.75	3.25	3.85	4.57
<b>45</b>	0.80	1.08	1.37	1.67	1.99	2.36	2.78	3.27	3.86
<b>50</b>	0.64	0.91	1.16	1.42	1.70	2.00	2.35	2.75	3.22
<b>55</b>	-	0.76	0.98	1.20	1.42	1.68	1.96	2.28	2.65
<b>60</b>	-	0.65	0.83	1.00	1.18	1.38	1.60	1.85	2.15

Operating conditions: suction superheat: 11.1 K, subcooling: 8.3 K

$t_c$  - Condensing temperature [°C]

$t_e$  - Evaporating temperature [°C]

### Application range

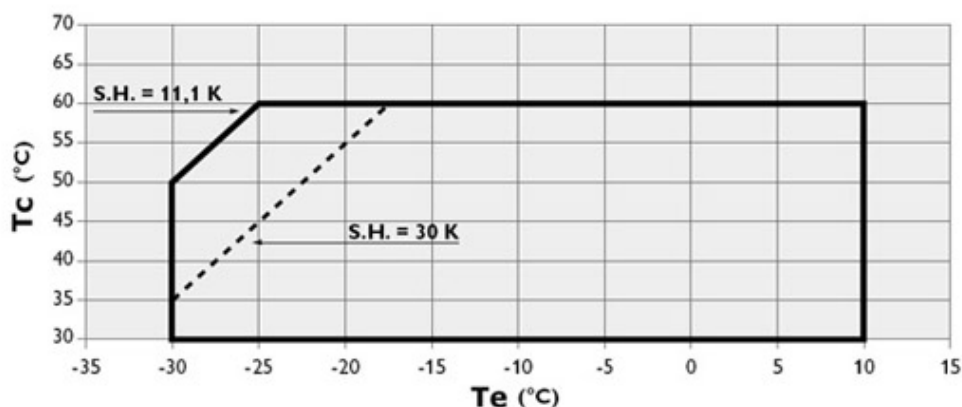

**R407C****Cooling capacity [W]**

<b>t<sub>c</sub> \ t<sub>e</sub></b>	<b>-15</b>	<b>-10</b>	<b>-5</b>	<b>0</b>	<b>5</b>	<b>10</b>	<b>15</b>
<b>35</b>	5 647	7 666	10 089	12 962	16 328	20 232	24 717
<b>40</b>	5 038	6 958	9 258	11 983	15 176	18 882	23 145
<b>45</b>	4 455	6 259	8 419	10 978	13 982	17 473	21 497
<b>50</b>	-	5 580	7 583	9 960	12 757	16 017	19 784
<b>55</b>	-	-	6 761	8 940	11 513	14 524	18 019
<b>60</b>	-	-	-	7 929	10 261	13 008	16 212
<b>65</b>	-	-	-	6 940	9 014	11 478	14 375

**Power input [W]**

<b>t<sub>c</sub> \ t<sub>e</sub></b>	<b>-15</b>	<b>-10</b>	<b>-5</b>	<b>0</b>	<b>5</b>	<b>10</b>	<b>15</b>
<b>35</b>	2 541	2 869	3 172	3 440	3 662	3 828	3 927
<b>40</b>	2 612	2 967	3 303	3 611	3 879	4 098	4 258
<b>45</b>	2 667	3 052	3 427	3 779	4 099	4 376	4 600
<b>50</b>	-	3 125	3 542	3 943	4 319	4 659	4 952
<b>55</b>	-	-	3 645	4 101	4 537	4 944	5 311
<b>60</b>	-	-	-	4 250	4 752	5 230	5 676
<b>65</b>	-	-	-	4 389	4 960	5 515	6 044

**Current [A]**

<b>t<sub>c</sub> \ t<sub>e</sub></b>	<b>-15</b>	<b>-10</b>	<b>-5</b>	<b>0</b>	<b>5</b>	<b>10</b>	<b>15</b>
<b>35</b>	5.70	6.07	6.42	6.73	7.01	7.23	7.40
<b>40</b>	5.77	6.18	6.57	6.94	7.28	7.58	7.83
<b>45</b>	5.82	6.27	6.72	7.15	7.57	7.95	8.29
<b>50</b>	-	6.35	6.86	7.36	7.85	8.32	8.76
<b>55</b>	-	-	6.99	7.57	8.15	8.71	9.25
<b>60</b>	-	-	-	7.77	8.44	9.11	9.76
<b>65</b>	-	-	-	7.97	8.74	9.51	10.28

**Mass flow [kg/s]**

$t_c \setminus t_e$	-15	-10	-5	0	5	10	15
<b>35</b>	112.28	149.58	193.30	244.12	302.71	369.76	445.94
<b>40</b>	104.65	141.95	185.53	236.09	294.29	360.82	436.36
<b>45</b>	97.23	134.11	177.16	227.04	284.44	350.04	424.51
<b>50</b>	-	126.28	168.37	217.17	273.35	337.61	410.62
<b>55</b>	-	-	159.38	206.69	261.25	323.76	394.89
<b>60</b>	-	-	-	195.80	248.33	308.67	377.51
<b>65</b>	-	-	-	184.71	234.79	292.56	358.70

**C.O.P. [W/W]**

$t_c \setminus t_e$	-15	-10	-5	0	5	10	15
<b>35</b>	2.22	2.67	3.18	3.77	4.46	5.29	6.29
<b>40</b>	1.93	2.35	2.80	3.32	3.91	4.61	5.44
<b>45</b>	1.67	2.05	2.46	2.91	3.41	3.99	4.67
<b>50</b>	-	1.79	2.14	2.53	2.95	3.44	4.00
<b>55</b>	-	-	1.85	2.18	2.54	2.94	3.39
<b>60</b>	-	-	-	1.87	2.16	2.49	2.86
<b>65</b>	-	-	-	1.58	1.82	2.08	2.38

Operating conditions: suction superheat: 11.1 K, subcooling: 8.3 K

$t_c$  - Condensing temperature [°C]

$t_e$  - Evaporating temperature [°C]

**Application range**

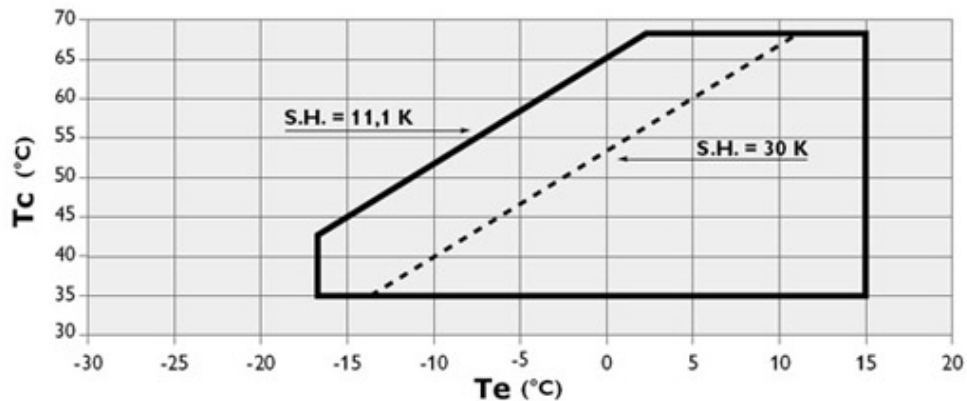

**GACO SARL**

28, Rue Bencharif Madani

25000 BELLEVUE/CONSTANTINE - ALGERIE

Tel. : 031 92 54 56 / 031 93 22 23 - Fax : 031 92 13 45

Email : gacosarl@gmail.com / benkobbi\_fares@yahoo.fr

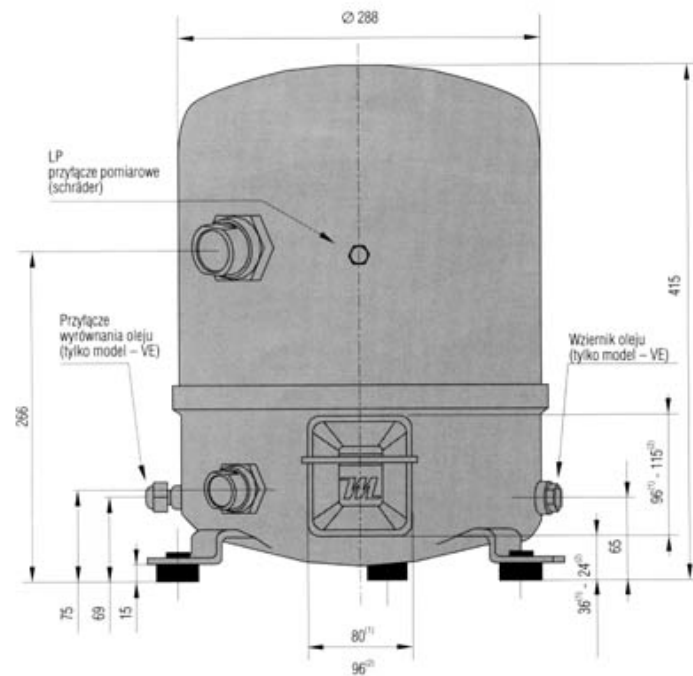
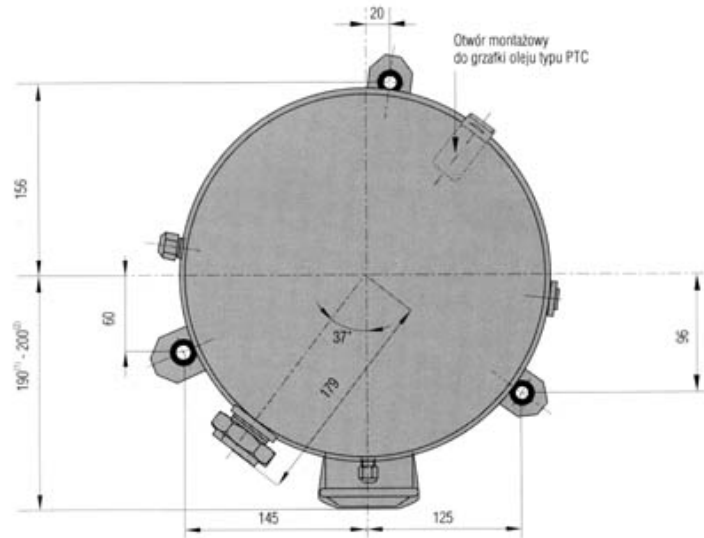



---

**GACO SARL**

28, Rue Bencharif Madani

25000 BELLEVUE/CONSTANTINE - ALGERIE

Tel. : 031 92 54 56 / 031 93 22 23 - Fax : 031 92 13 45

Email : gacosarl@gmail.com / benkobbi\_fares@yahoo.fr



## Single phase power supply

### Electrical data

Motor voltage code:	1	5
Starting current [A]:	136	
Maximum Continuous Current (MCC) [A]:	42,5	
Winding resistance (between phases) (run/start) [ $\Omega$ ]:	0,32/1,61	/

### PSC starting with additional winding

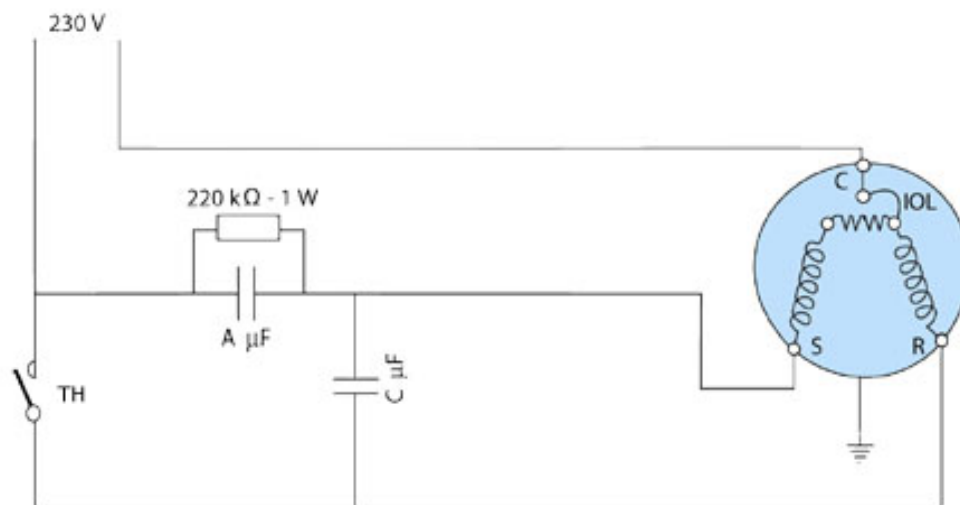

IOL: inner motor protection (klixon)

A, C: main condensers

C: starting condenser / S: common

TH: thermostat

SR: movement transmitter

## CSR starting with additional winding

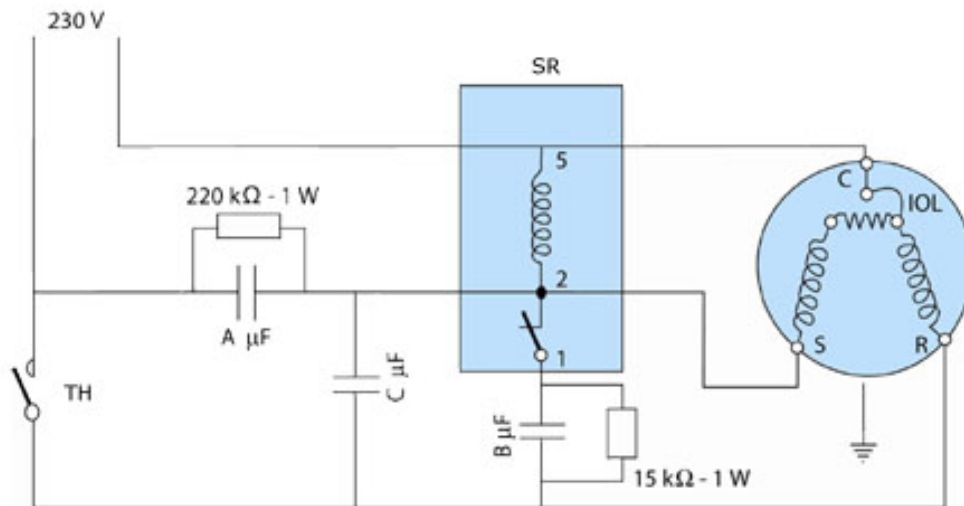

IOL: inner motor protection (klixon)

A, C: main condensers

B: starting condenser

C: common / S: additional starting winding

TH: thermostat

SR: movement transmitter

## CSR starting without additional winding

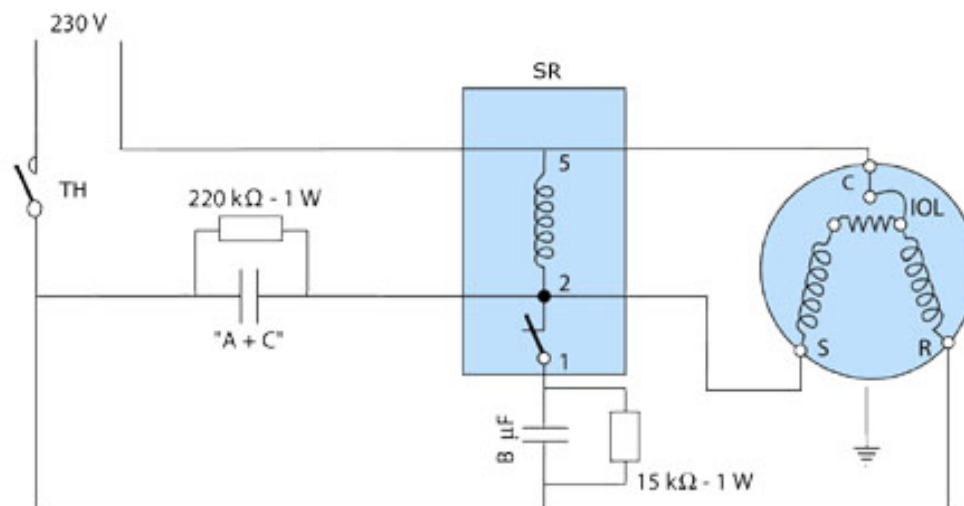

IOL: inner motor protection (klixon)

A, C: main condensers

B: starting condenser

C: common / S: additional starting winding

TH: thermostat

SR: movement transmitter

condensers A and C are replaced by one condenser of capacity A + C

## Three-phase power supply

### Electrical data

Motor voltage code:	3	4	6	7	9
Starting current [A]:	130	60	105	50	72
Maximum Continuous Current (MCC) [A]:	26	12	105	11	15
Winding resistance (between phases) [ $\Omega$ ]:	0,57	2,41	0,76	3,86	-

### Connection diagram for systems without refrigerant suction

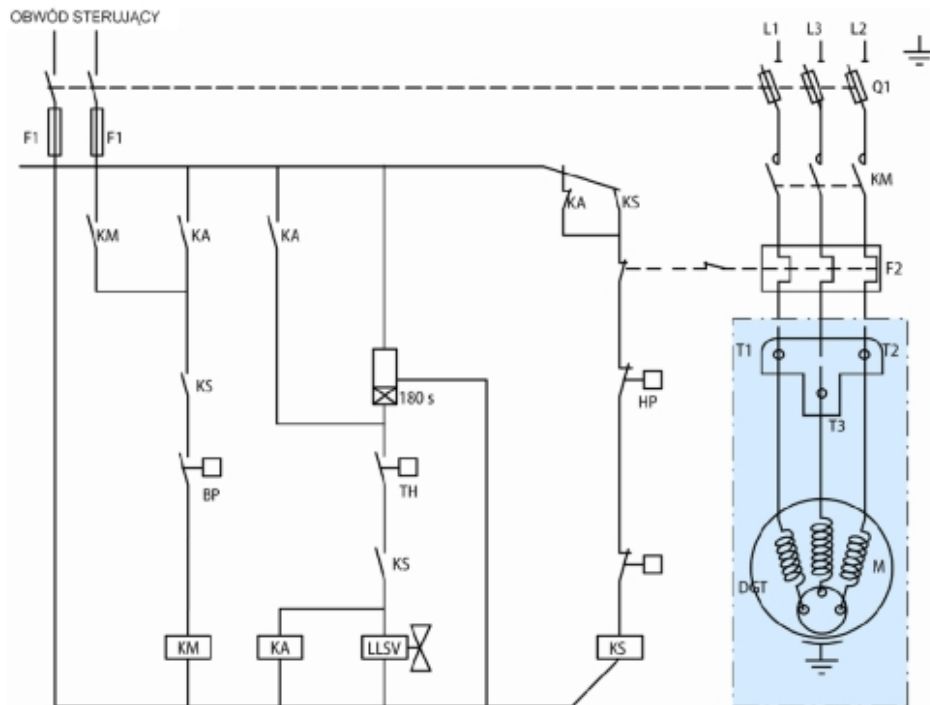

TH: Thermostat

180 s: Optional short cycle timer (3min) 5 pts

KA: Control relay

LLSV: Liquid Solenoid valve

KM: Compressor contactor

KS: Safety lock out relay

BP: Low pressure switch

HP: High pressure switch

Q1: Fused disconnect

F1: Fuses

F2: External overload protection

M: Compressor's engine

thM: Motor safety thermostat

DGT: Discharge gas thermostat

## Connection diagram for systems with refrigerant suction

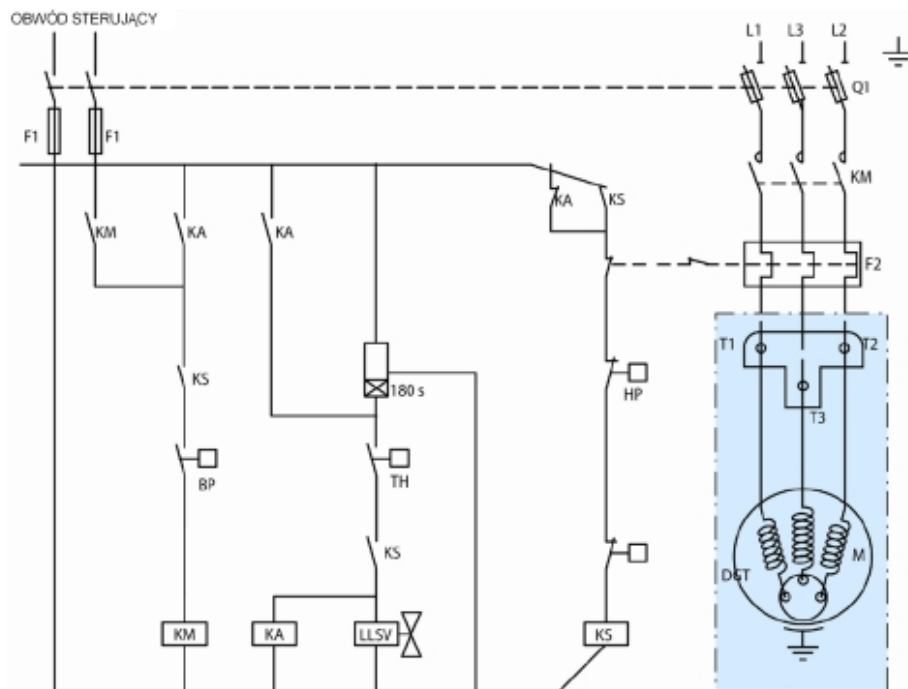

TH: Thermostat

180 s: Optional short cycle timer (3min) 5 pts

KA: Control relay

LLSV: Liquid Solenoid valve

KM: Compressor contactor

KS: Safety lock out relay

BP: Low pressure switch

HP: High pressure switch

Q1: Fused disconnect

F1: Fuses

F2: External overload protection

M: Compressor's engine

thM: Motor safety thermostat

DGT: Discharge gas thermostat

---

**GACO SARL**

28, Rue Bencharif Madani

25000 BELLEVUE/CONSTANTINE - ALGERIE

Tel. : 031 92 54 56 / 031 93 22 23 - Fax : 031 92 13 45

Email : [gacosarl@gmail.com](mailto:gacosarl@gmail.com) / [benkobbi\\_fares@yahoo.fr](mailto:benkobbi_fares@yahoo.fr)

---



## **Equipment**

- ▶ crankcase heater - PTC 35 W
- ▶ belt type heater - crankcase heater 65W, 230V
- ▶ Rotolock valves
  - suction: Rotolock valve connection 1 3/4", connection with supplied sleeve 7/8"
  - discharge: Rotolock valve connection 1 1/4", connection with supplied sleeve 3/4"
- ▶ soft-start kit - electronic softstart MCI 15C
- ▶ accoustic hood - acoustic shield of Danfoss catalogue number 7755002